

VALVE-REGULATED LEAD ACID BATTERIES: INDIVIDUAL DATA SHEET

LC-R127R2P



For main and standby power supplies.
Expected trickle life: 3-5 years at 25°C, Approx. 5 years at 20°C.

Dimensions (mm)

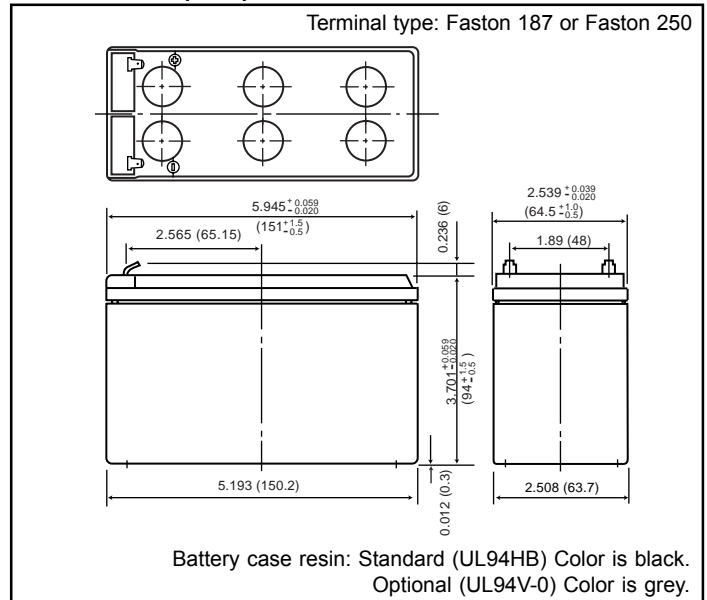

Specifications

Nominal voltage		12V
Rated capacity (20 hour rate)		7.2Ah
Dimensions	Length	5.945 inches (151.0 mm)
	Width	2.539 inches (64.5 mm)
	Height	3.702 inches (94.0 mm)
	Total Height*	3.937 inches (100.0 mm)
Approx. mass		5.45 lbs (2.47 kg)
Standard Terminals and Resin	UL94HB Faston 187	LC-R127R2P
	UL94HB Faston 250	LC-R127R2P1
Optional Terminals and Resin	UL94V-0 Faston 187	◆ LC-V127R2P
	UL94V-0 Faston 250	◆ LC-V127R2P1

* The total height with #250 terminal is 101.5mm.

◆ Please contact Panasonic for availability on optional items. Optional items may be subject to minimum order quantities.

Discharge characteristics 77°F (25°C) (Note)

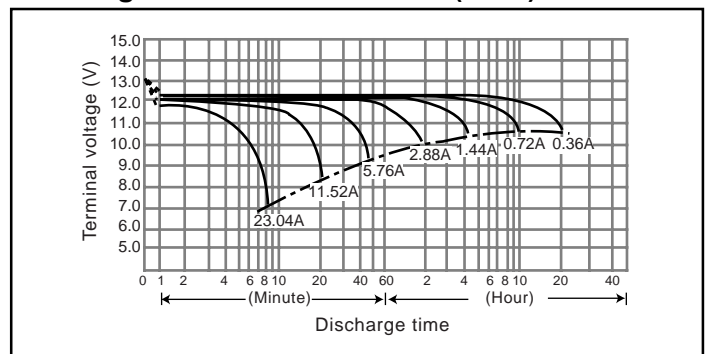

Characteristics

Capacity (note) 77°F (25°C)	20 hour rate (360mA)	7.2Ah	
	10 hour rate (680mA)	6.8Ah	
	5 hour rate (1260mA)	6.3Ah	
	1 hour rate (4900mA)	4.9Ah	
	1.5 hour rate discharge Cut-off voltage 10.5 V	3.5A	
Internal resistance	Fully charged battery 77°F (25°C)	Approx. 40mΩ	
Temperature dependency of capacity (20 hour rate)	104°F (40°C)	102%	
	77°F (25°C)	100%	
	32°F (0°C)	85%	
	5°F (-15°C)	65%	
Self discharge 77°F (25°C)	Residual capacity after standing 3 months	91%	
	Residual capacity after standing 6 months	82%	
	Residual capacity after standing 12 months	64%	
Charge Method (Constant Voltage)	Cycle use (Repeating use)	Initial current	2.88 A or smaller
		Control voltage	14.5V to 14.9 V (per 12V cell 25°C)
	Trickle use	Initial current	1.08 A or smaller
		Control voltage	13.6V to 13.8V (per 12V cell 25°C)

(Note) The above characteristics data are average values obtained within three charge/discharge cycles not the minimum values.

Duration of discharge vs. Discharge current (Note)

